



**Model FS4010,
M1 through M4
Free Space Test System
80MHz–4.2GHz
10 Volts per Meter**

The Models FS4010, FS4010M1, and FS4010M2 are pre-compliance test systems designed for RF radiated immunity and emissions testing. They are designed for applications requiring field strengths of up to 10 volts per meter (V/m) with 80%AM or 20 V/m CW. They consist of a set of solid state broadband RF power amplifiers, a semi-anechoic test chamber, a broadband electric field monitoring probe, a signal generator, a power meter, dual directional couplers, a RF switch matrix, a color printer, interconnecting RF cables and connectors and a system control PC pre-loaded with radiated immunity and emissions testing software to automate the testing process. It also includes a pre-amplifier and interconnecting cables for use with a user supplied Spectrum Analyzer (included in M3 and M4 versions).

The system components of the FS4010 models are listed in Table 1.

The immunity and emissions test software provides automated testing, data collection and report generation. The simple user interface facilitates test parameter selection and setup of a "Thresholding" mode for pre-compliance investigation of equipment susceptibility. Control of closed loop field leveling has also been incorporated making the program suitable for pre-compliance troubleshooting, testing to the IEC-801-3 (1984) standard, and MIL STD 461 type testing using a broadband electric field monitoring probe.

Instrument control is provided via a National Instruments IEEE-488 interface card.

Automatic data acquisition for EUT monitoring and data collection is supported by a National Instruments data acquisition card to allow the user to automatically collect and record, for report generation, EUT performance data from up to 8 digital and 16 analog channels (pass / fail conditions). An additional 8 digital output lines are available for EUT control or reset. The test cell provides access via 9 filtered lines. Additional line access can be added by the user on a user modifiable access plate.

The Model FS4010 free space test system affords a cost effective method of equipping an automated pre-compliance radiated immunity and emissions test facility using an economical compact free space test cell suitable for an EUT size up to 1.0 meter per side. The test cell offers the user a large access door (1.8m (H) x 1.0m (W) opening) with viewing window, interior illumination, fiber optic access pipe, 15 amp, 110/220 VAC single phase filtered mains connection, door open safety interlock and Type N coaxial thru connector. The test cell enclosure is nominally 5.7m (W) x 2.6m (H) x 2.4m (D).

The interior of the cell is lined with a radio frequency absorbing material to create a self contained semi-anechoic enclosure. The field inside the cell is generated by an internal log periodic antenna. Field polarization is switchable for vertical or horizontal.

Equipment supporting the cell is housed in a rack cabinet of desk configuration with nominal footprint of 1.8m (W) x 1.0m (D). This configuration provides a convenient tabletop location for the PC, monitor, keyboard, mouse, and printer.

SPECIFICATIONS

TABLE 1 – MODEL FS4010 SYSTEM COMPONENTS

(Please refer to individual specification sheets for information describing these items)

ITEM	DESCRIPTION	MODEL				
		FS4010 80MHz-1000MHz	FS4010M1 80MHz-3GHz	FS4010M2 80MHz-4.2 GHz	FS4010M3 80MHz-3 GHz	FS4010M4 80MHz-4.2 GHz
1	Semi-anechoic free space test cell, AR Model TC4000B, 80MHz-4.2GHz	•	•	•	•	•
2	RF Power Amplifier, AR Model/150W1000M3, 150 Watts CW, 80MHz – 1000MHz	•	•	•	•	•
2a	RF Power Amplifier, AR Model 120S1G3, 120 Watts CW, 0.8GHz – 3.0GHz		•		•	
2b	RF Power Amplifier, AR Model 100S1G4, 100 Watts CW, 0.8GHz – 4.2GHz			•		•
3	Isotropic "E" Field Probe, AR Model FL7006 kit, 100kHz-6.0GHz, 0.5-800V/m	•	•	•	•	•
4	Probe stand for AR field probes, Model PS2000	•	•	•	•	•
5	Dual Directional Coupler, AR Model DC6080, 80MHz – 1000MHz, 40dB, 200 Watts	•	•	•	•	•
5a	Dual Directional Coupler, AR Model DC7144A, 0.8GHz-4.2GHz, 40dB, 400 Watts		•	•	•	•
6	Signal Generator, Model SG1200, 9kHz-1.2GHz, 1kHz AM modulation, 0.1dBm step attenuator	•				
6a	Signal Generator, Model SG6000, 100kHz – 6GHz, 1kHz AM Modulation, 0.1dBm step attenuator		•	•	•	•
7	Power Meter, AR Model PM2002 w/PH2000 Sampling Head, 10kHz-8GHz, -60dBm sensitivity	•	•	•	•	•
8	Color Printer, 600+ DPI resolution with printer cable	•	•	•		
9	Controller PC (2GHz Pentium 4 or better) with GPIB (NI,PCI-GPIB) and DAQ (NI, PCI-6025E) cards pre-installed	•	•	•	•	•
10	Radiated and Conducted Immunity and Emissions Test Software, AR Model SW1006. Installed on controller PC	•	•	•	•	•
11	Assorted RF Cables	•	•	•	•	•
12	Assorted GPIB Interface Cables: (2) 1m and (1) 2m lengths	•	•	•	•	•
13	Preamplifier, AR Model LN1000BM2 for emissions testing with user supplied spectrum analyzer	•	•	•	•	•
14	RF System Controller (switch matrix), AR Model SC1000M1, dc-18GHz,	•	•	•	•	•
15	Noise Emitter, AR Model NE3000, 9kHz-2GHz				•	•
16	Spectrum Analyzer, 9kHz-3GHz				•	•

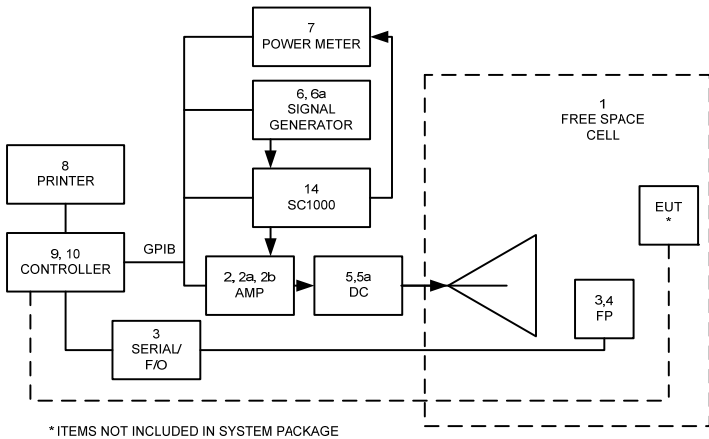

SYSTEM BLOCK DIAGRAM (IMMUNITY)

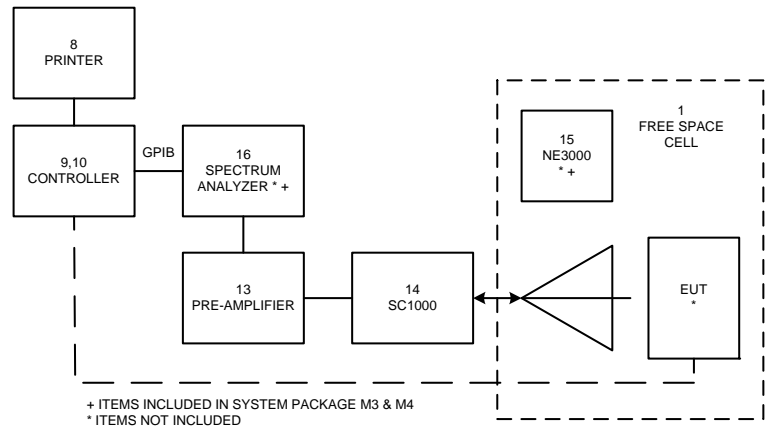

SYSTEM BLOCK DIAGRAM (EMISSIONS)